

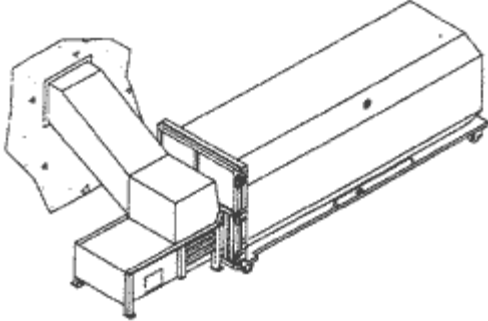

Stationary Compactors Standard Installations

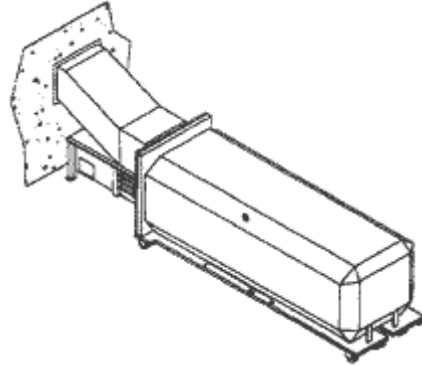

Typical side-loading security-chute with inside U/L security fire door



Typical rear loading security chute with inside U/L security fire door

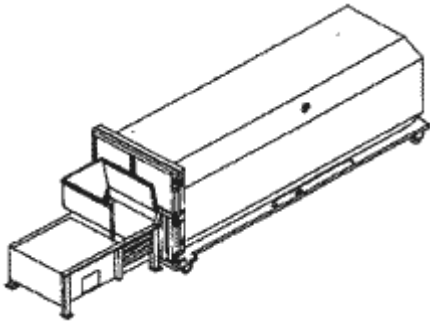

Typical ground loading open dog house

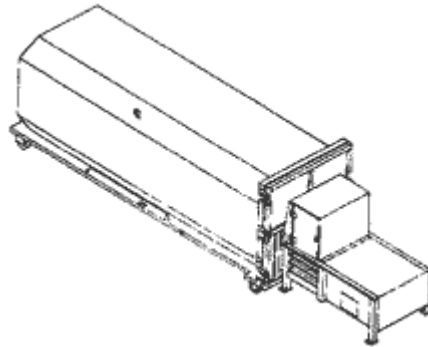

Typical ground loading 2-door lockable dog house enclosure

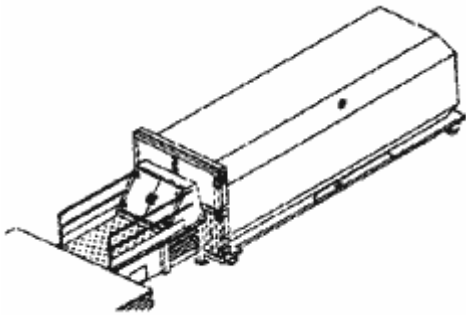

Typical dock loading bulkhead enclosure with safety rails, gate and diamond plate decking

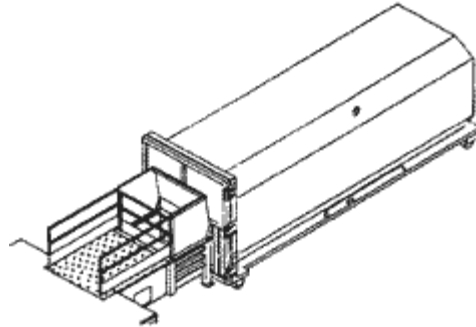

Typical dock loading open hopper extension with safety rails, gate and diamond plate decking



Stationary Compactors Specifications

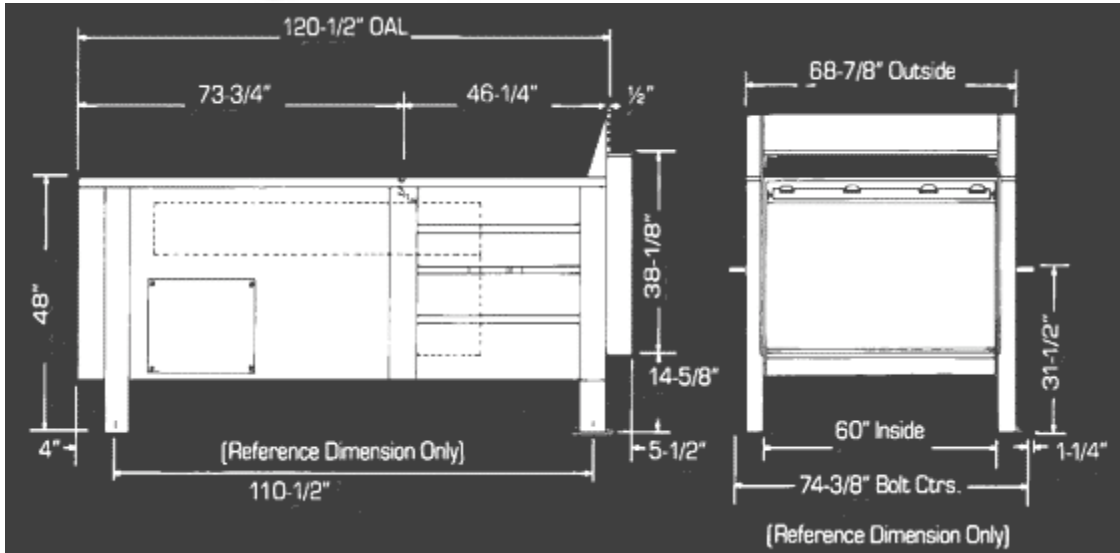

DIMENSIONS FOR 2 CUBIC YARD STATIONARY COMPACTOR UNIT
(Shown without accessories)